

Dear Sir or Madam:

Thank you for your choice. Before installing and using the units, please carefully read and follow the instructions described in this manual.

If there is any problem, please call your installation contractor.

## 1. System Instructions

Family ground source heat pumps system can be applied in the independent and small scale space, such as multilayered apartments, villas, restaurants and entertainment places etc.

The ground source heat pumps system consists of 3 main components:

1. Main unit: there are two kinds of types: cooling only and heat pump (cooling and heating). It is usually placed in outdoor balcony, storeroom or special platform.

2. Indoor units: we recommend you to use super-thin and low noise horizontal built-in fan coil units.

3. Water system: mainly used for connecting the main unit and terminals to transfer the cold and hot sources. Galvanized tubes are commonly used.

The system is controlled singly for every room. The main unit operates automatically under the control of computer. What users need to do is just operate the indoor controller.

## 2. Family central air conditioning system

### 2.1 Main Unit

#### a. Sketch map of WRB09

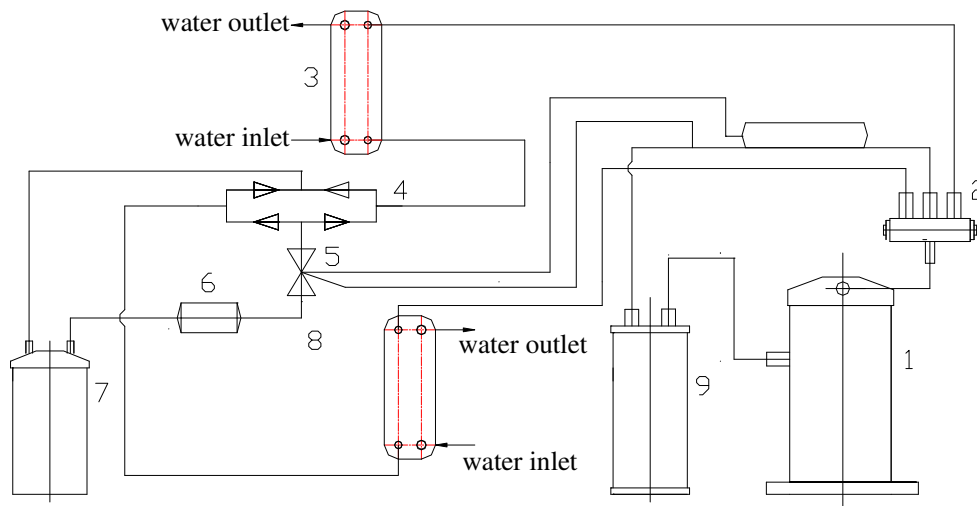

Principle diagram of cooling system

1. compressor    2. 4-way valve    3. condenser    4. one-way valve group    5. expansion valve  
 6. filter    7. high pressure accumulator    8. evaporator    9. air-liquid separator

b. Data sheet of WRB09

Item	Type		WRB09
	Unit		
			09
Cooling capacity	kW		8.45
Heating capacity	kW		9.16
Power input (cooling/heating)	kW		2.10/ 2.76
Power supply			3N□50Hz 380V
Refrigerant type			R407c, R22
Refrigerant charge			kg 2.1
Water pump	Brand		GRUNDFOS
	Shut-off head	mH <sub>2</sub> O	8.1
	Power input	kw	0.25
Condenser	Type		Brazing plate heat exchanger
	Nominal flow	t/h	1.57
	Hydraulic pressure drop	Mpa	0.01
	Pipe fitting sizes	inch	1
Evaporator	Type		Brazing plate heat exchanger
	Nominal flow	t/h	1.45
	Hydraulic pressure drop	Mpa	0.01
	Pipe fitting sizes	Inch	1
Dimensions	Length	mm	1270
	Width	mm	640
	Height	mm	810
Weight			kg 235

Note - Cooling working condition: chilled water inlet/outlet temperature:12°C/7°C□cooling water inlet/outlet temperature: 20°C/25°C.

Heating working condition: chilled water inlet/outlet temperature:12°C/7°C□cooling water inlet/outlet temperature: 40°C/45°C.

*Data in this table are subject to change without notice.*

- Principle diagram of cooling system  
 1.compressor 2. 4-way reverse valve 3.plate heat exchanger  
 4. capillary 5. filter 6. finned heat exchanger 4.fan

c. Sketch map of WAHP05H

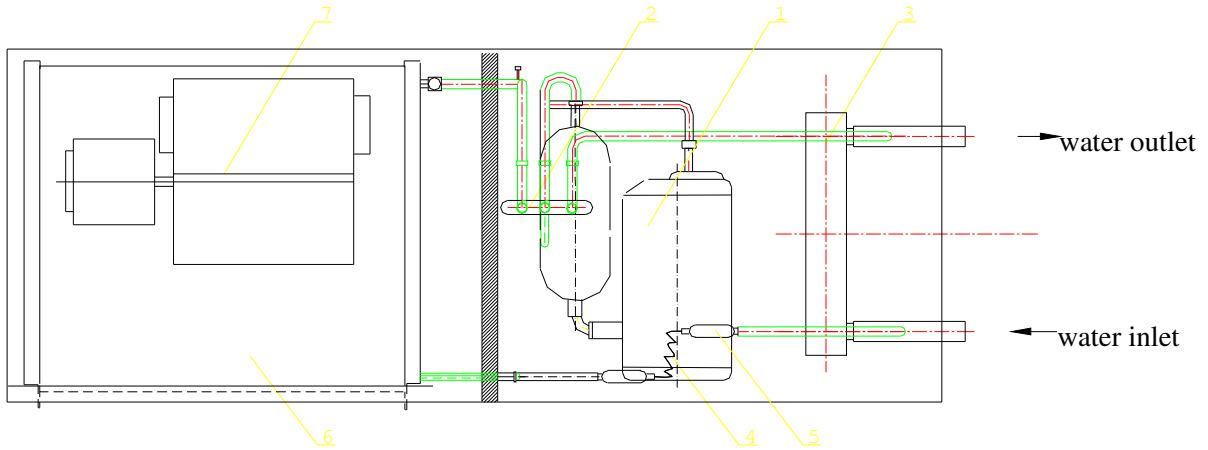

Principle diagram of cooling system

- 1.compressor 2. 4-way reverse valve 3.plate heat exchanger  
 4. capillary 5. filter 6. finned heat exchanger 4.fan

d. Sketch map of WAHP05V

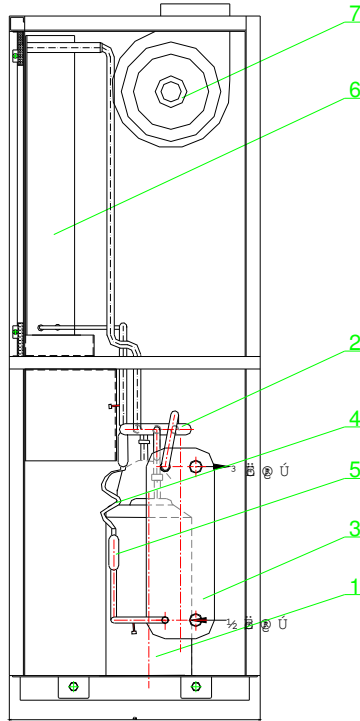

Principle diagram of cooling system

- 1.compressor 2.4-way reverse valve; 3.plate heat exchanger  
 4.capillary 5. filter 6. finned heat exchanger 7. fan

e. Data sheet of WAHP05

Item	Type		WAHP05
	Unit		
			05
Cooling capacity		kw	3.72
Heating capacity		kw	4.96
Power input (Cooling/Heating)		kw	1.11/ 1.32
Power supply			1N□50Hz 220V
Refrigerant type			R407c, R22
Refrigerant charge		kg	1.5
Indoor fan	Wind pressure	Pa	70.8
	Nominal air flow	l/s	208
	Power input	kw	0.075
Water side heat exchanger	Type		Brazing plate heat exchanger
	Nominal flow	t/h	0.8
	Hydraulic pressure drop	Mpa	0.01
	Pipe fitting sizes	in	3/4
Dimensions (V/H)	Length	mm	550/1150
	Width	mm	410/450
	Height	mm	1135/450
Weight		kg	65

Note□Cooling working condition: air inlet temperature:26°C□ water inlet/ temperature: 30°C.

Heating working condition: air inlet temperature:21°C□ water inlet/ temperature: 20°C.

*Data in this table are subject to change without notice.*

## 2.2 Indoor units

You can choose various types of fan coil units as the indoor units according to different room styles. We recommend you to choose the super-thin horizontal built-in fan coil units because they are hidden well and the noise index is low.

## 3. Installation

### 3.1 Installation of main unit

#### □ Installation site

- The unit can be installed in storeroom, special platform or other suitable places.
- Should leave enough space surround the unit for maintenance.
- Near the power supply.
- No heat sources and other devices' vent, no heat vapor and flammable gas around the units.

#### □ How to install

- Fit the unit with expansion bolts directly, also can use angle iron with shock-proof gaskets as support and put it on the ground, make sure that the unit be placed horizontally.
- When move the unit, the gradient should less than 45°.

### 3.2 Installation of indoor units

The installation must be reliable, convenient and conform to the relative regulations.

### 3.3 Water system connection

#### 3.3.1 Well water side

- Select right pump.
- Select corresponding pipe diameter and install the flow switch in the water inlet pipe.

#### 3.3.2 User side

- The right pump has been installed in the main unit.
- Select right pipe diameter according to the outlet diameter of the main unit and ensure that the unit runs in order.

#### 3.3.3 Piping connection

- The piping connection must comply with the relevant piping standards.
- Reduce the bends as possible as you can in order to decrease the loss of water resistance.
- Set the automatic charge valve at the highest part of the water supply/return pipe to discharge the air in the water system during test run. Set the drain valve at the lowest part of the return water pipe to empty the water in the water system.
- Must install the water filter where the water inlet pipe located in order to avoid a clog of plate heat exchanger in the unit.
- According to relevant regulations to undergo a water pressure leak testing and remove the dirt after connecting the pipes. Keep the system clean to avoid any damage of the piping, plate heat

exchanger and water pump due to the clog.

- After passing the qualification test should wrap the water pipes in the heat-protection layer which is no less than  $\delta 15\text{mm}$ .
- The pressure differential type feed water solenoid valve and the cutoff valve of the indoor water system must be installed in the rooms to avoid any damage due to freezing.

**WARNING** Must install the water filter on the water inlet pipe and clean it regularly.

### 3.4 Electric installation

3.4.1 Use AC 1N.50Hz 220V or 3N 50Hz 380V according to the models the fluctuating range of the voltage must less than +5% 10%.

3.4.2 The main unit must be fixed with appropriate breaker or air switch.

3.4.3 Select appropriate wires whose sections are not less than  $4\text{mm}^2$  for the main unit.

3.4.4 The main unit should be grounded reliably.

3.4.5 Wiring of the main unit

- a Remove the door plate of the connection box and connect the power supply wire with the corresponding terminals.
- b Use the insulating wire ( $\geq 1\text{mm}^2$ ) as the communication line, the numbers of which are 1,2,3,4,5,6,7. Connect the communication line to the indoor controller.
- c Terminals 1 and 13 connect to the water flow switch of the system.
- d Terminals 1 and 14 connect to the flow switch in the well water side.
- e Terminals 2 and 28 connect to the contactor winding of the water pump in the water source side.

3.4.6 Terminals 1,13,1,14 can't be short connected.

3.4.7 Operation instruction of indoor controller (please refer to the enclosed document).

**WARNING** Before installation and maintenance, must shut off the power supply.

### 3.5 Note:

If the unit is cooling only, must install the drain valve at the lowest part of the water system piping. If the unit will be shut down during the winter months, the unit should be emptied of water to avoid any damage due to freezing.

## 4. System test

4.1 Charge the refrigerant

#### 4.1.1 Heat pump system:

Fill the whole system with special anti-freezing refrigerant from the water return pipe with the manual pressure pump and make sure to exhaust the air in it.

#### 4.1.2 Cooling only system

Fill the whole system with water from the water return pipe with manual pressure pump and make sure to exhaust the air in it.

#### 4.2 Checks before test run

##### 4.2.1 Check the indoor fan coil units

A  Check the power supply and the operation direction of the fan.

B  Check if the inlet /outlet valves of the piping system are all opened.

C  Check if there is air in the fan coil unit, should discharge it by discharge valve.

##### 4.2.2 Check the piping system

A  Check if the installation of water filter and the selection of filter mesh are correct or suitable.

B  Check if the return water and static pressure are normal.

C  Check all piping system if the water flow is sufficient and if the air has been exhausted.

D  Check if the valves in the system are all opened.

E  Check if the heat-preservation of the piping system is well.

##### 4.2.3 Check the wiring system

A  Check the voltage and wiring connection.

B  Check the screws of the parts and check if the wiring meets the safe requirements.

C  Check if the shell has been grounded well.

D  Exhaust the air in the pipes with discharge valves.

##### 4.2.4 Check the outdoor unit

A  Check if the appearance is damaged during transportation or move.

B  Check if the piping connection is correct.

#### 4.3 Test run

Test run of the unit must be carried out by a qualified technician.

4.3.1 Electrify the unit, move the switch SA2 to Cooling/Heating and the switch SA1 to ON according to the “Operation instruction of indoor controller”. At this time, the cycle water pump should run steadily. It indicates that there is air in the water system or other causes if the pump is screaming. You should stop the unit and exhaust the gas and then restart the unit. The compressor is started after 3 minutes. Continue the running if there aren't abnormal sounds in the unit.

4.3.2 In the summer, when the return water temperature in the user's side is not less than 15℃, the compressor is started until the temperature is lower than 12℃. The compressor will restart

automatically when the temperature is not less than 15°F again.

4.2.3 In the winter, when the return water temperature in the user's side is not less than 35°F, the compressor is started until the temperature rises to 40°F. The compressor will restart automatically when the temperature is not less than 35°F again.

4.2.4 Check the temperatures of water inlet and outlet, the temperature difference of 3°F or so is ok (should refer to the water flow).

4.2.5 Clean the filter after the test run of the new system.

## **5. Maintenance**

1□ If there are not any problems after the test run, users can operate by the indoor controller.

2□ All safety devices have been set before leaving the factory, don't make any adjustment, otherwise, we are not responsible for any damage due to it.

3□ Don't turn off all the switches arbitrarily.

4□ Don't clog the air outlets and air return vents of the indoor fan coil units.

5□ Don't close the valves in the water outlet or inlet arbitrarily.

6□ Don't shut off the power supply after stopping the unit in the winter. If the unit is stopped for a long time (over 2days)□ must warm up the compressor for more than 6 hours before restarting.

7□ The water in the unit and the water system should be emptied to avoid any damage of water pump, plate heat exchanger and water piping due to freezing. Fill the system with water according to the relative instructions of the manual when reuse the unit.

## 6. Troubleshooting

If there is any problem of system, please call the qualified technician. The following table can act as a reference for them to resolve the problems.

<b>Familiar faults</b>	<b>Causes</b>	<b>Action</b>
1 <input type="checkbox"/> Compressor can't be started.	1 <input type="checkbox"/> Power supply fault 2 <input type="checkbox"/> The set point of temperature controller is too high or too low 3 <input type="checkbox"/> Connection is loose 4 <input type="checkbox"/> Relay or fuse fault 5 <input type="checkbox"/> Compressor fault	Find out the causes. Reset Check and repair. Check and repair. Change the compressor
2 <input type="checkbox"/> Compressor is started and stopped frequently.	1 <input type="checkbox"/> Too much or too less refrigerant 2 <input type="checkbox"/> Bad water recycle 3 <input type="checkbox"/> The difference set point of temperature controller is too low	Check leak and charge or discharge some refrigerant Water system is clogged or has gas in it, check the pump and valve piping, clean the water filter or exhaust the gas. Reset
3 <input type="checkbox"/> Compressor noise is big.	1 <input type="checkbox"/> Liquid refrigerant has gone to the compressor 2 <input type="checkbox"/> Parts inside the compressor damaged.	Check the expansion. Check the sensor Change the compressor
4 <input type="checkbox"/> Low cooling capacity.	1 <input type="checkbox"/> Lack of refrigerant 2 <input type="checkbox"/> Bad heat-preservation of water system 3 <input type="checkbox"/> Lack of water flow 4 <input type="checkbox"/> Cooling system is clogged.	Check the leak and charge the refrigerant Preserve the heating of the piping. Clean the water filter. Check or change the dry filter.
5 <input type="checkbox"/> Water pump does not run or screams.	1 <input type="checkbox"/> Power supply fault 2 <input type="checkbox"/> Relay fault 3 <input type="checkbox"/> Pump motor is damaged 4 <input type="checkbox"/> There is gas in water system	Check the power supply and repair it Change the relay Change the pump motor Exhaust the gas
6 <input type="checkbox"/> High pressure switch acts frequently.	1 <input type="checkbox"/> Too much refrigerant 2 <input type="checkbox"/> Water flow too slow 3 <input type="checkbox"/> High pressure switch fault	Discharge the excessive refrigerant. Check the water flow Change the high pressure switch
7 <input type="checkbox"/> Water pump is stopped.	1 <input type="checkbox"/> Check the power supply of the water pump 2 <input type="checkbox"/> Starting capacitor fault 3 <input type="checkbox"/> Water pump fault	Find out the causes Change the capacitor Change the water pump
8 <input type="checkbox"/> Compressor is running but the unit does not cool.	1 <input type="checkbox"/> Refrigerant leaks all. 2 <input type="checkbox"/> Plate heat exchanger is frozen 3 <input type="checkbox"/> Compressor fault	Find the leak, repair and charge the refrigerant. Find out the cause and change the plate heat exchanger Change the compressor

